

VectorStar®

Multiport, High Performance, Broadband Network Analysis Solutions

MN469xC Series Vector Network Analyzer Multiport Test Sets

Introduction

This document provides the specifications for the MN469xC series Multiport Vector Network Analyzers (VNAs) test sets listed below, when used in conjunction with the 2-port MS464xA/B series VectorStar VNA. These MN469xC specifications are based upon the MS464xA/B series VNA specifications, which can be found at www.anritsu.com/vectorstar. The MS464xA/B specifications are referenced throughout this document.

Test Set Models:

- MN4694C 4-port, K (2.92 mm), 70 kHz* to 20/40 GHz
- MN4697C 4-port, V (1.85 mm), 70 kHz* to 50/70 GHz

*Operational to 40 kHz

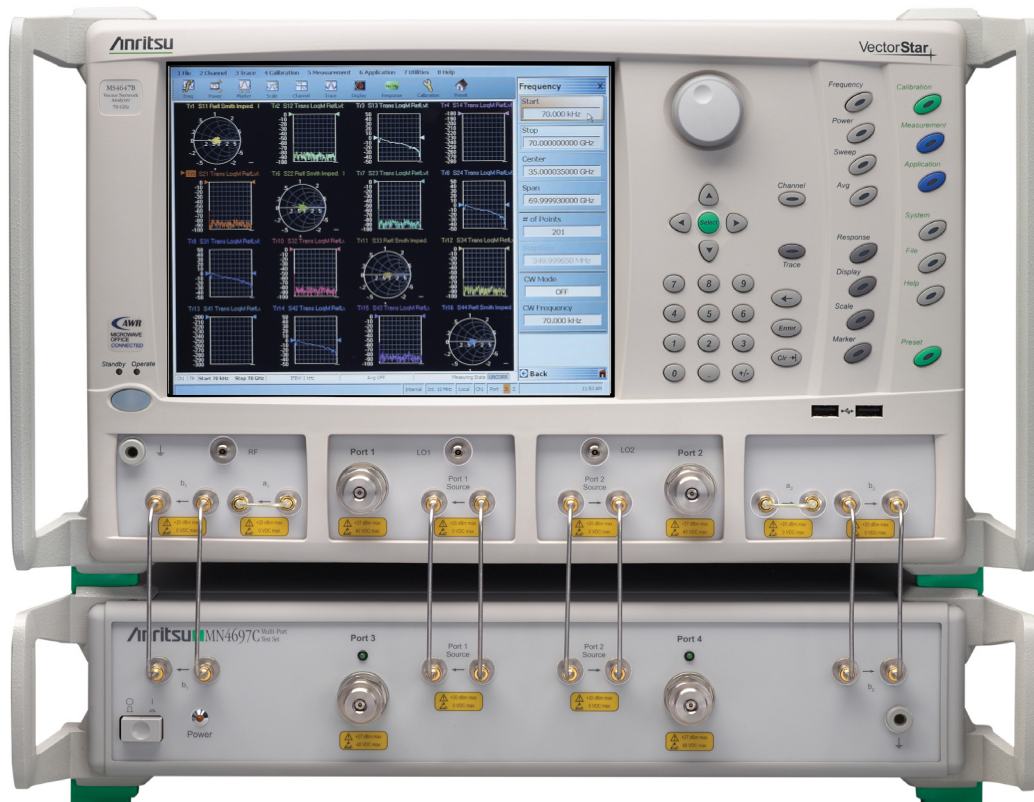

Minimum MS464xA/B Series 2-port VNA Configuration required: MS464xA/B VNA with Option 051, Direct Access Loops

Description	Page
1. Definitions	2
2. System Block Diagram	3
3. System Performance	4
3.1 Test Port Power, Noise Floor, System Dynamic Range	4
3.2 Receiver Compression, Receiver Dynamic Range	5
3.3 High Level Noise	5
3.4 Measurement Stability	5
3.5 Phase Noise, Harmonics and Non-Harmonics (Spurious)	5
3.6 Uncorrected (Raw) Port Characteristics	6
3.7 Corrected System Performance and Uncertainties	7
4. Remote Operability	11
5. Capabilities and Calibrations Added to the Base 2-Port VNA	11
6. Front Panel Connections	11
7. Rear Panel Connections	12
8. Mechanical and Environmental	13
9. Warranty	13
10. Ordering Information	13
11. Configuration Guide	14

1. Definitions

	All specifications and characteristics apply under the following conditions, unless otherwise stated:
Warm-Up Time	After 90 minutes of warm-up time, where the instrument is left in the ON state.
Temperature Range	Within 25 °C ± 5 °C.
Error-Corrected Specifications	For error-corrected specifications, at 23 °C ± 3 °C, with < 1 °C variation from calibration temperature. Error-corrected specifications are warranted and include guard bands, unless otherwise stated.
Typical Performance	"Typical" specifications describe expected, but not warranted, performance based on sample testing. Typical performance indicates the measured performance of an average unit and do not guarantee the performance of any individual product. "Typical" specifications do not account for measurement uncertainty and are shown in parenthesis, such as (-102 dB), or noted as Typical.
User Cables	Specifications do not include effects of any user cables attached to the instrument.
Discrete Spurious Responses	Specifications may exclude discrete spurious responses.
Internal Reference Signal	All specifications apply with internal 10 MHz Crystal Oscillator Reference Signal.
Characteristic Performance	Characteristic performance indicates a performance designed-in and verified during the design phase. It does include guard-bands and is not covered by the product warranty.
Below 300 kHz	All uncertainties below 300 kHz are typical.
Recommended Calibration Cycle	12 months
Interpolation Mode	All specifications are with Interpolation Mode Off.
Specifications Subject to Change	All specifications subject to change without notice. For the most current data sheet, please visit the Anritsu web site at www.anritsu.com .

2. System Block Diagram

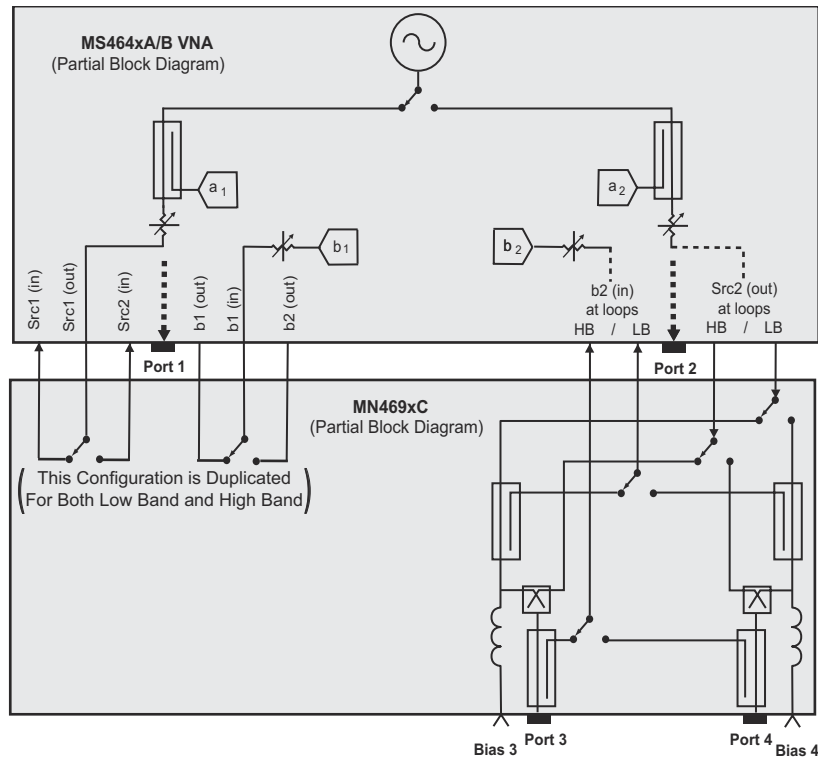

Figure 1-1. MS464xA/B VNA

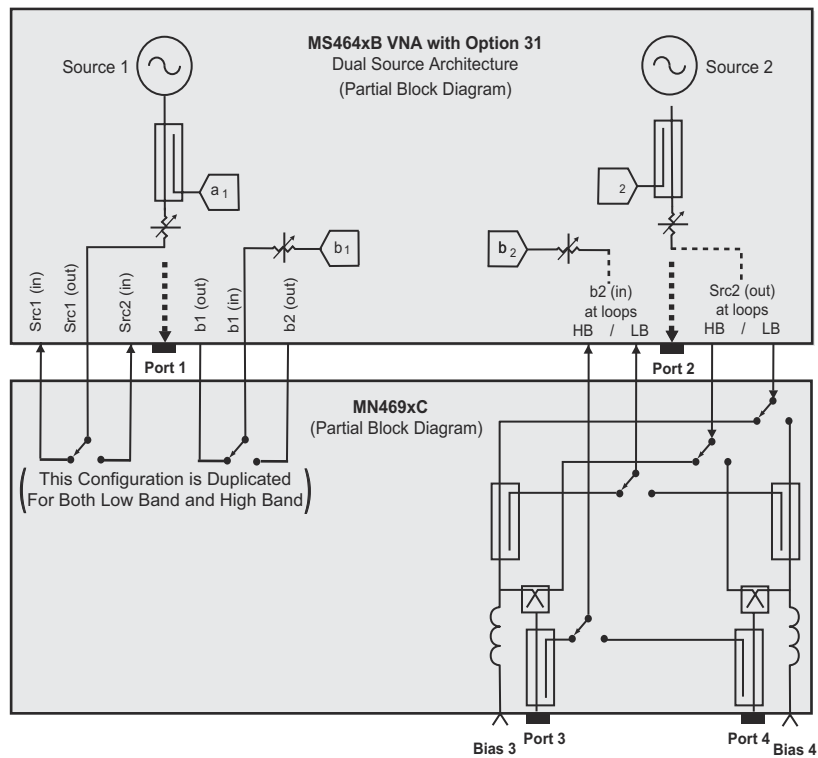

Figure 1-2. MS464xB VNA With Option 31 Dual Source Architecture

3. System Performance

System performance is specified when connected to a base 2-port VNA with option 051 (Direct Access Loops). If additional options are added to the base VNA that affects its port performance, those affects must also be added to these system specifications. For example, adding option 06x, Active Measurements Suite, will affect available test port power and dynamic range.

The MN469xC series test sets only contribute loss to the source and test paths, and uncorrected (raw) port directivity and match. Therefore, a limited set of system performance parameters are shown below as specifications verified on each system. All other parameters are listed as Characteristic Performance. They are tested and verified during the design phase. Some of these parameters are solely a contribution of the base VNA and not affected by the test set.

3.1 Test Port Power, Noise Floor, System Dynamic Range

MN4694C with MS4642A/B or MS4644A/B, 20 GHz or 40 GHz Models

Frequency Range	Power (dBm) ^a	Noise Floor ^b (dBm)	System Dynamic Range ^c (dB)
0.07 to 2 MHz	+4	-72	76
> 2 to 10 MHz	+6	-94	100
> 0.01 to 2.5 GHz	+7	-102	109
> 2.5 to 18 GHz	+8	-106	114
> 18 to 26 GHz	+4	-104	108
> 26 to 40 GHz	+5	-106	111

MS464xB with Option 031

0.07 to 2 MHz	+6	-72	78
> 2 to 10 MHz	+8	-94	102
> 0.01 to 2.5 GHz	+12	-102	114
> 2.5 to 18 GHz	+11	-106	117
> 18 to 26 GHz	+8	-104	112
> 26 to 40 GHz	+10	-106	116

MN4697C with MS4645A/B or MS4647A/B, 50 GHz or 70 GHz Models

Frequency Range	Power (dBm)	Noise Floor ^a (dBm)	System Dynamic Range ^b (dB)
0.07 to 2 MHz	+4	-72	76
> 2 to 10 MHz	+6	-94	100
> 0.01 to 2.5 GHz	+8	-102	110
> 2.5 to 16 GHz	+3	-106	109
> 16 to 24 GHz	-2	-104	102
> 24 to 38 GHz	+1	-106	107
> 38 to 46 GHz	-3	-100	97
> 46 to 50 GHz	-8	-98	90
> 50 to 60 GHz	-8	-98	90
> 60 to 67 GHz	-12	-94	82
> 67 to 70 GHz	-16	-86	70

MN4697C with Option 031

0.07 to 2 MHz	+6	-72	78
> 2 to 10 MHz	+8	-94	102
> 0.01 to 2.5 GHz	+12	-102	114
> 2.5 to 16 GHz	+7	-106	113
> 16 to 24 GHz	+4	-104	108
> 24 to 38 GHz	+4	-106	110
> 38 to 46 GHz	-1	-100	99
> 46 to 50 GHz	-2	-98	96
> 50 to 60 GHz	-2	-98	96
> 60 to 67 GHz	-6	-94	88
> 67 to 70 GHz	-7	-86	79

a. Power measured at the test set port, not the VNA set power

b. Measured at 10 Hz IF bandwidth with no averaging and at a -10 dBm power setting, RMS. Leakage correction applied below 200 MHz. Measurement is made with a through line connection, compensating for its effects. Typical test set insertion loss used in noise floor measurements.

c. Calculated as the difference between the maximum test port power and the specified noise floor.

3.2 Receiver Compression, Receiver Dynamic Range

(All Models)

Frequency Range	Receiver 0.1 dB Compression ^a (dBm)	Receiver Dynamic Range ^b (dB)
0.07 to 0.5 MHz	+5	77
> 0.5 to 2 MHz	+10	85
> 2 to 10 MHz	+13	107
> 0.01 to 2.5 GHz	+13	115
> 2.5 to 20 GHz	+14	119
> 20 to 40 GHz	+15	115
> 40 to 50 GHz	+15	113
> 50 to 65 GHz	+15	109
> 65 to 70 GHz	+15	101

a. Port power level beyond which the response may be compressed by more than 0.1 dB relative to the normalization level (0.17 dB, < 300 kHz). 10 Hz IFBW is used to remove any trace noise effects. Match not included. Performance is characteristic.

b. Calculated as the difference between the maximum receiver input level for 0.1 dB compression and the specified noise floor. Performance is characteristic.

3.3 High Level Noise

Measured at 1 kHz IFBW at default power with either full reflects or through transmission, RMS. Performance is characteristic.

Frequency Range	MN4694C		MN4696C	
	Magnitude (dB) ^a	Phase (degrees)	Magnitude (dB) ^a	Phase (degrees)
0.07 to 0.5 MHz	0.040	0.40	0.040	0.40
> 0.5 MHz to 40 GHz	0.005	0.05	0.006	0.06
> 40 to 50 GHz	n/a	n/a	0.007	0.07
> 50 to 65 GHz	n/a	n/a	0.008	0.08
> 65 to 70 GHz	n/a	n/a	0.030	0.30

a. Some degradation may occur in systems that have Option 031 combined with Option 084 or Option 085. For a description of Option 031, 084, and 085, refer to the Technical Data Sheet 11410-00611.

3.4 Measurement Stability

Ratio measurement with ports shorted. Performance is characteristic.

Frequency Range	Magnitude (dB/°C)	Phase (degrees/°C)
0.07 to 10 MHz	< 0.04	< 0.4
> 0.01 to 2.5 GHz	< 0.03	< 0.4
> 2.5 to 20 GHz	< 0.04	< 0.5
> 20 to 50 GHz	< 0.06	< 0.8
> 50 to 65 GHz	< 0.07	< 1.1
> 65 to 70 GHz	< 0.10	< 1.1

3.5 Phase Noise, Harmonics and Non-Harmonics (Spurious)

Measured at default power. Performance is characteristic.

Frequency Range	SSB Phase Noise at 10 kHz offset (dBc/Hz)	Harmonics (second and third) (dBc)	Non-Harmonic Spurious at > 1 kHz offset (dBc)
0.07 to 10 MHz	-78	-20	-20
> 0.01 to 2.5 GHz	-84	-20	-30
> 2.5 to 20 GHz	-72	-20 ^a	-30
> 20 to 40 GHz	-66	-20	-30
> 40 to 50 GHz	-61	-20	-30
> 50 to 65 GHz	-61	-20	-30
> 65 to 70 GHz	-61	-20	-30

a. May degrade by 3 dB (typical) between 2.5 and 2.7 GHz.

3.6 Uncorrected (Raw) Port Characteristics

Performance is characteristic.

Frequency Range	Directivity (dB)	Port Match ^a (dB)
0.07 to 10 MHz	> 10 ^b	> 8
> 0.01 to 2.5 GHz	> 9 ^b	> 10
> 2.5 to 20 GHz	> 17	> 9
> 20 to 40 GHz	> 15	> 7
> 40 to 50 GHz	> 13	> 7
> 50 to 65 GHz	> 11	> 7
> 65 to 70 GHz	> 8	> 7

a. Port Match is defined as the worst of source and load match.

b. < 300 kHz and 200 MHz below 2.5 GHz: 4 dB (typical).

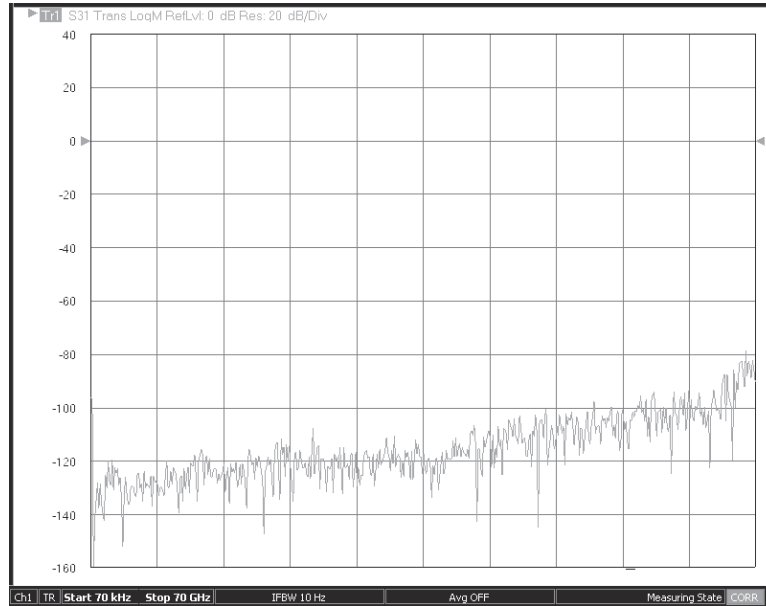

System Dynamic Range (as measured, not RMS). 10 Hz IFBW, no averaging, at max power, ports terminated after transmission calibration.

3.7 Corrected System Performance and Uncertainties

MN4694C with MS4642A/B or MS4644A/B, 20 GHz or 40 GHz Models with full SOLT Cal (3 Thrus) using the 3652A K Cal Kit.

Frequency Range (GHz)	Directivity (dB)	Source Match (dB)	Load Match ^a (dB)	Reflection Tracking (dB)	Transmission Tracking (dB)
≤ 0.01	> 38	> 36	> 38	±0.02	±0.05
> 0.01 to 2.5	> 37	> 41	> 37	±0.005	±0.03
> 2.5 to 20	> 34	> 39	> 35	±0.006	±0.07
> 20 to 40	> 32	> 34	> 32	±0.006	±0.08

a. Since Residual Load Match is limited by Residual Directivity and the user test port cable, it can only be specified as Residual Directivity. For practical considerations, derate it by ~ 8 dB for a 3670 series test port cable to compensate for affects such as match, repeatability, bend radius, etc.

Measurement Uncertainties

The graphs give measurement uncertainties after the above calibration. The errors are worst case contribution of residual directivity, load and source match, frequency response and isolation, network analyzer dynamic accuracy, and connector repeatability. An IF bandwidth of 10 Hz is used. For transmission uncertainties, it is assumed that $s_{11} = s_{22} = 0$. For reflection uncertainties, it is assumed that $s_{21} = s_{12} = 0$. All calibrations and measurements were performed at 0 dBm or default port power, whichever is less. For other conditions, please use our free Exact Uncertainty Calculator software, available from www.anritsu.com.

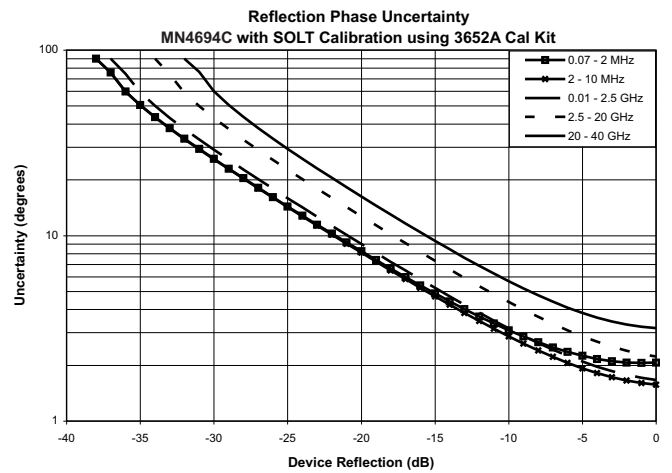
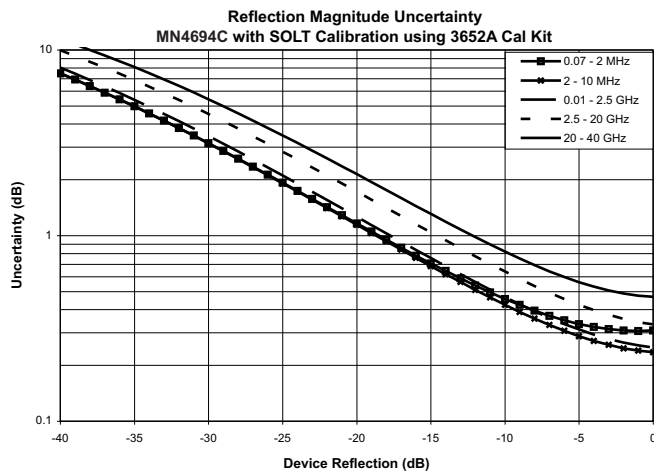
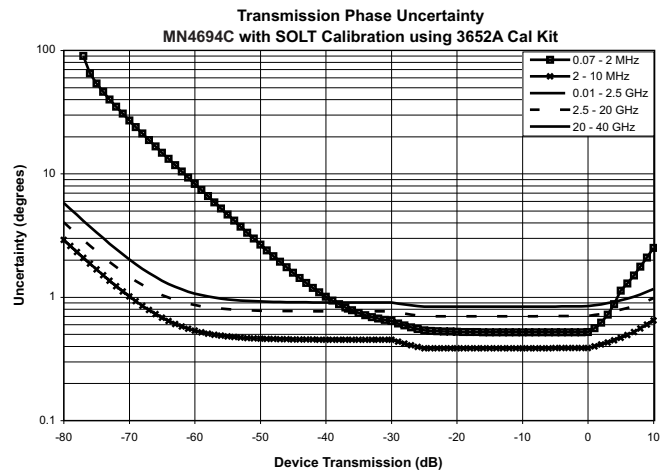
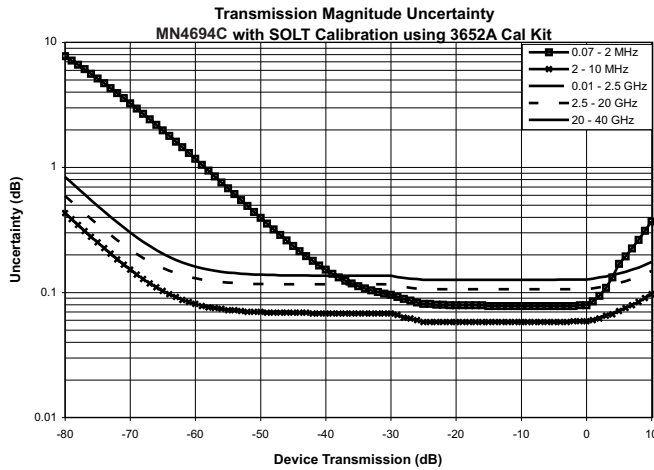

MN4694C with MS4642A/B or MS4644A/B, 20 GHz or 40 GHz Models, with full cal using two precision AutoCal steps and an external thru using the 36585K K AutoCal.

Frequency Range (GHz)	Directivity (dB)	Source Match (dB)	Load Match ^a (dB)	Reflection Tracking (dB)	Transmission Tracking (dB)
≤ 0.01 ^b	> 40	> 43	> 43	±0.10	±0.10
> 0.01 to 2.5	> 43	> 47	> 43	±0.05	±0.03
> 2.5 to 20	> 50	> 47	> 50	±0.09	±0.03
> 20 to 40	> 48	> 47	> 48	±0.14	±0.07

a. Since Residual Load Match is limited by Residual Directivity and the user test port cable, it can only be specified as Residual Directivity. For practical considerations, derate it by ~ 8 dB for a 3670 series test port cable to compensate for affects such as match, repeatability, bend radius, etc.

b. Typical performance below 2 MHz.

Measurement Uncertainties

The graphs give measurement uncertainties after the above calibration. The errors are worst case contribution of residual directivity, load and source match, frequency response and isolation, network analyzer dynamic accuracy, and connector repeatability. An IF bandwidth of 10 Hz is used. For transmission uncertainties, it is assumed that $s_{11} = s_{22} = 0$. For reflection uncertainties, it is assumed that $s_{21} = s_{12} = 0$. All calibrations and measurements were performed at 0 dBm or default port power, whichever is less. For other conditions, please use our free Exact Uncertainty Calculator software, available from www.anritsu.com.

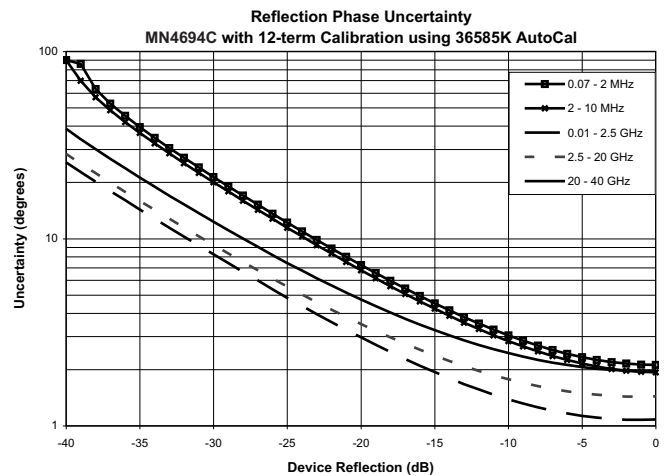
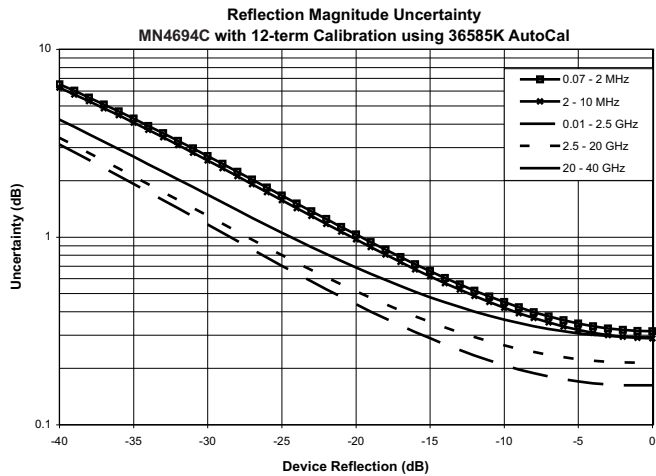
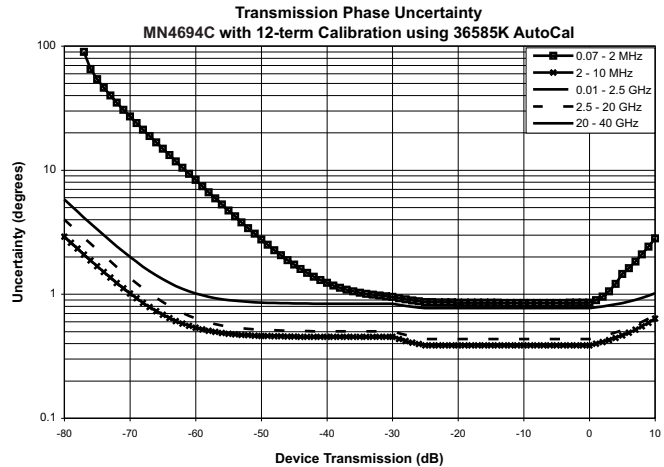
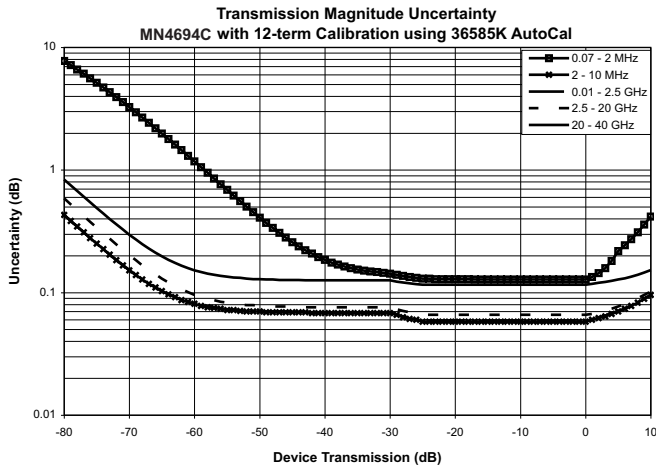

MN4697C with MS4645A/B or MS4647A/B, 50 GHz or 70 GHz Models with full SOLT Cal (3 Thrus) using the 3654D V Cal Kit.

Frequency Range (GHz)	Directivity (dB)	Source Match (dB)	Load Match ^a (dB)	Reflection Tracking (dB)	Transmission Tracking (dB)
≤ 0.01	> 38	> 36	> 38	±0.02	±0.05
> 0.01 to 2.5	> 40	> 39	> 40	±0.02	±0.05
> 2.5 to 20	> 40	> 37	> 40	±0.02	±0.07
> 20 to 40	> 35	> 32	> 35	±0.02	±0.08
> 40 to 65	> 32	> 28	> 32	±0.08	±0.12
> 65 to 67	> 32	> 28	> 32	±0.15	±0.15
> 67 to 70	> 28	> 26	> 28	±0.30	±0.15

a. Since Residual Load Match is limited by Residual Directivity and the user test port cable, it can only be specified as Residual Directivity. For practical considerations, derate it by ~ 8 dB for a 3670 series test port cable to compensate for effects such as match, repeatability, bend radius, etc.

Measurement Uncertainties

The graphs give measurement uncertainties after the above calibration. The errors are worst case contribution of residual directivity, load and source match, frequency response and isolation, network analyzer dynamic accuracy, and connector repeatability. An IF bandwidth of 10 Hz is used. For transmission uncertainties, it is assumed that $s_{11} = s_{22} = 0$. For reflection uncertainties, it is assumed that $s_{21} = s_{12} = 0$. All calibrations and measurements were performed at 0 dBm or default port power, whichever is less. For other conditions, please use our free Exact Uncertainty Calculator software, available from www.anritsu.com.

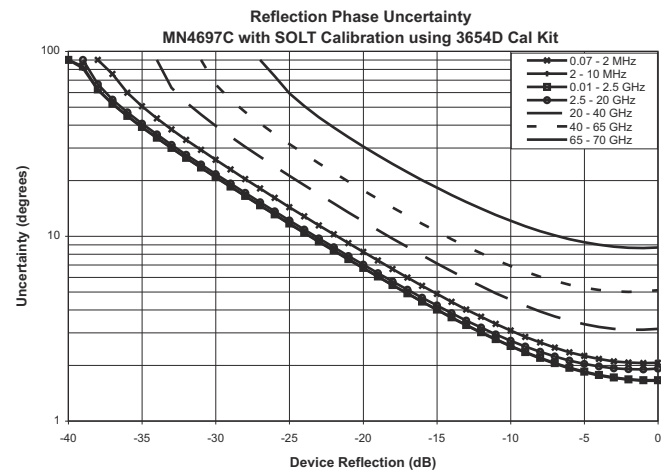
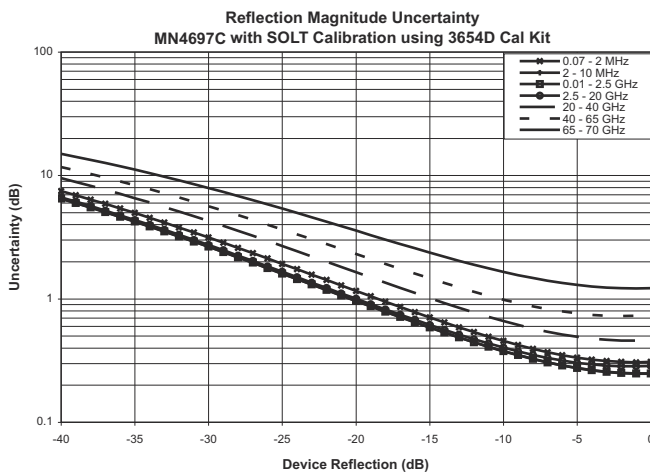
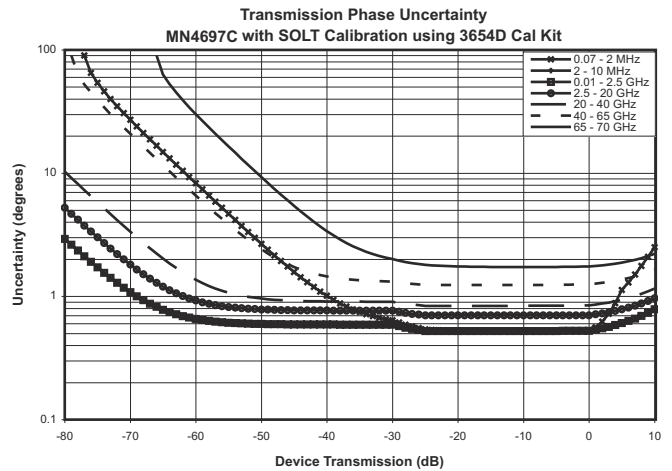
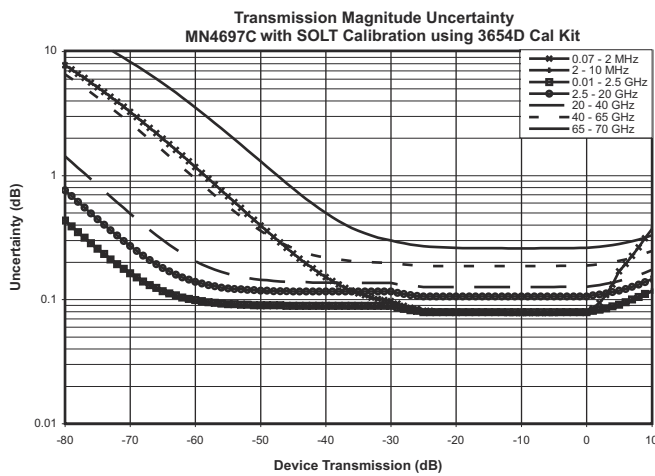

MN4697C with MS4645A/B or MS4647A/B, 50 GHz or 70 GHz Models with full calibration using two precision AutoCal steps and an external thru using the 36585V V AutoCal.

Frequency Range (GHz)	Directivity (dB)	Source Match (dB)	Load Match ^a (dB)	Reflection Tracking (dB)	Transmission Tracking (dB)
≤ 0.01 ^b	> 40	> 40	> 40	±0.10	±0.10
> 0.01 to 2.5	> 43	> 47	> 43	±0.05	±0.03
> 2.5 to 20	> 50	> 47	> 50	±0.09	±0.03
> 20 to 40	> 48	> 47	> 48	±0.14	±0.07
> 40 to 65	> 43	> 45	> 43	±0.17 ^c	±0.10
> 65 to 67	> 43	> 45	> 43	±0.17	±0.10
> 67 to 70	> 42	> 40	> 42	±0.30	±0.12

a. Since Residual Load Match is limited by Residual Directivity and the user test port cable, it can only be specified as Residual Directivity. For practical considerations, derate it by ~ 8 dB for a 3670 series test port cable to compensate for effects such as match, repeatability, bend radius, etc.

b. Typical performance below 2 MHz.

c. ±0.25 dB between 51 GHz to 55 GHz.

Measurement Uncertainties

The graphs give measurement uncertainties after the above calibration. The errors are worst case contribution of residual directivity, load and source match, frequency response and isolation, network analyzer dynamic accuracy, and connector repeatability. An IF bandwidth of 10 Hz is used. For transmission uncertainties, it is assumed that $s_{11} = s_{22} = 0$. For reflection uncertainties, it is assumed that $s_{21} = s_{12} = 0$. All calibrations and measurements were performed at 0 dBm or default port power, whichever is less. For other conditions, please use our free Exact Uncertainty Calculator software, available from www.anritsu.com.

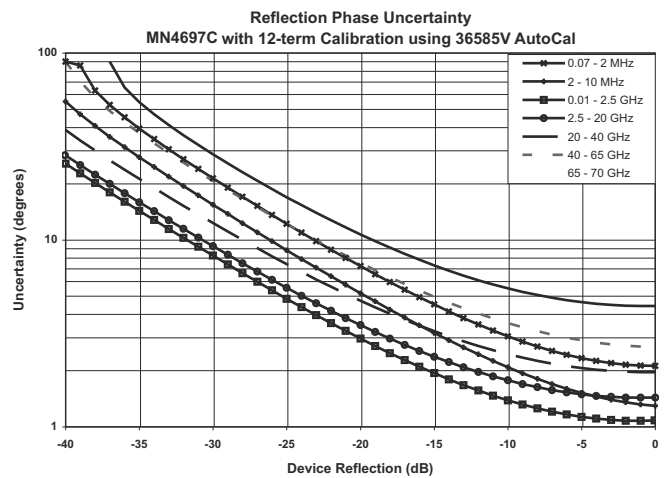
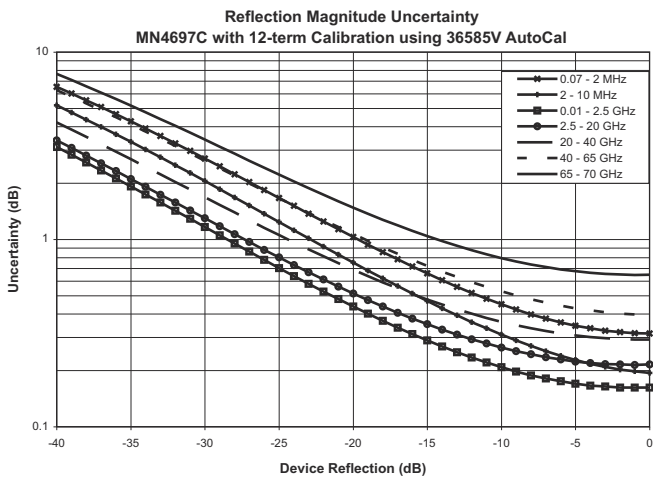
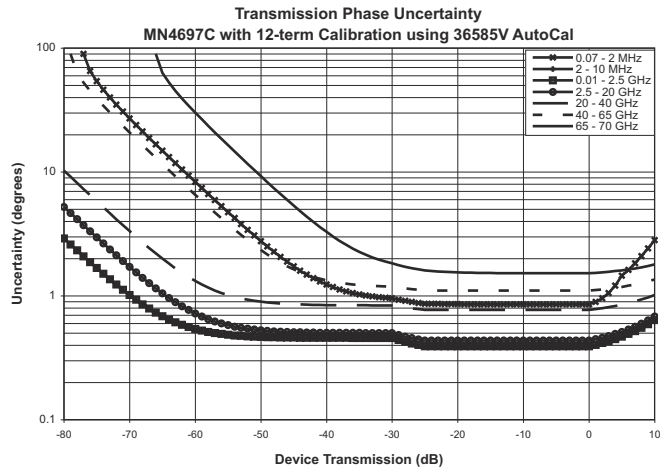
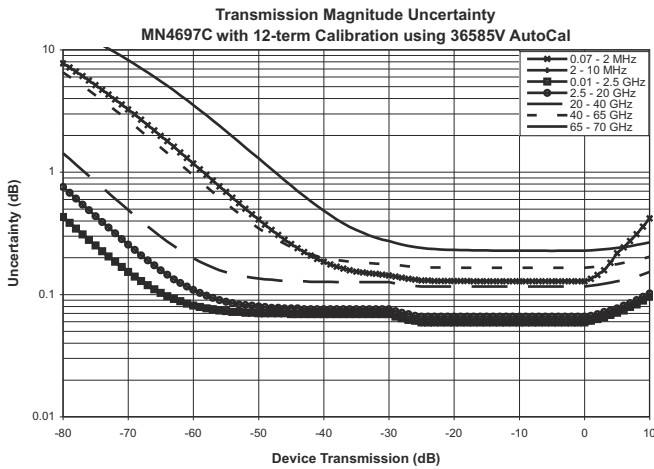

4. Remote Operability

Check the base MS464xA/B VNA data sheet for remote operability. The 4-port system is controllable via GPIB, LAN, and USB through the base VNA. The test set itself is controlled via GPIB by the base VNA and not intended to be controlled directly by the user.

5. Capabilities and Calibrations Added to the Base 2-Port VNA

When the VNA application detects an MN469xC series test set on its GPIB bus upon loading, it automatically goes into 4-port mode making available the following capabilities:

Measurement Parameters	16 single-ended S-parameters and any user-defined combination of a1-4, b1-4, and 1. 16 mixed-mode S-parameters (DD, CC, DC, CD); Uses the superposition technique, which is ideal and highly accurate for linear devices and measurements.
Correction Models	Using 2-port precision AutoCal: <ul style="list-style-type: none"> • 1-port Cals (ports 1 to 4) • 2-port Cals (single, double, full, 1 path 2 ports) • 4-port Cals (uses two AutoCal steps and up to 4 external thru/reciprocal, minimum of 1) Using standard Cal kits: <ul style="list-style-type: none"> • Transmission Frequency Response (between any 2 ports and any direction) • Reflection Frequency Response (ports 1 to 4) • 1-port Cals (ports 1 to 4) • 2-port Cals (single, double, full, 1 path 2 ports) • 3-port Cals (uses one full 2-port cal, one full 1-port cal, and up to 2 additional thru/reciprocal, minimum of 1) • 4-port Cals (uses two full 2-port cals and up to 4 additional thru/reciprocal, minimum of 1)
Calibration Methods	All existing calibration methods are available: SOLT, SSLT, SSST, SOLR, SSLR, SSSR, LRL, LRM, A-LRM, with one exception that LRL, LRM, and Reciprocal cannot be used for ports 1 to 2 and ports 3 to 4 combinations when using the external 4-port test set.
Bias Tees	Bias tees are available in the source path of each port 3 and port 4 0.4 A max, 40 VDC 3 kHz BW (nominal), looking into a high impedance 10 M ohms to ground for static discharge protection Located at rear panel

6. Front Panel Connections

Test Ports 3, and 4	Universal test port connectors are easily exchangeable in case of damage. K (male) for MN4694C; V (male) for MN4697C Damage Input Levels: +20 dBm max, 40 VDC max
Source Inputs from VNA	Interconnects to VNA port 1 source and port 2 source (4 each) K (female) for MN4694C; V (female) for MN4697C B reference outputs to VNA
High Band	Interconnects to VNA front panel high band b1 and b2 (4 each) K (female) for MN4694C; V (female) for MN4697C



MN469xC Test Set Front Panel and Connections to Base VNA

7. Rear Panel Connections

B Reference Outputs to VNA (Low Band)	Interconnects to VNA rear panel low band b1 and b2 (4 each) SMA (female)
	Interconnects to VNA rear panel port 1 source and port 2 source (4 each)
Bias Inputs	For ports 3 to 4, respectively; BNC (female) (2 each + fuses)
GPIB Port	Type D-24, female, IEEE 488.2 compatible (controllable only by the base VNA)
Aux IO	DB 9, 9 pin connector for system interfacing
AC Power Input	AC input connector, fused (250 V, 2 A) 150 VA max, 85 to 240 VAC, 47 to 63 Hz



MN469xC Test Set Rear Panel and Connections to Base VNA

8. Mechanical and Environmental

Dimensions	Height	89 mm (2U) 108 mm between feet outer edges
	Width	426 mm body 457 mm between feet outer edges
	Depth	502 mm body 591 mm between handle and foot outer edges
	Weight Fully Loaded	< 10 kg
Environmental (Operating)		
	Conforms to MIL-PRF-28800F (Class 3)	
Temperature Range	0 °C to +50 °C without error codes*	
Relative Humidity	5 % to 95 % at +40 °C	
Altitude	4,600 m	
* Except for 'unleveled' error messages that may occur at temperatures outside of the specified performance temperature range of 25 °C ± 5 °C.		
Environmental (Non-Operating)		
Temperature Range	-40 °C to +75 °C	
Relative Humidity	0 % to 90 % at +65 °C (non-condensing)	
Altitude	15,200 m	
Emissions Conformity		
EMI	Meets the emissions and immunity requirements of: <ul style="list-style-type: none"> • EN55011/1991 Class A/CISPR-11 Class A • EN50082-1/1993 • IEC 801-2/1984 (4 kV CD, 8 kV AD) • IEC 1000-4-3/1995 (3 V/m, 80-1000 MHz) IEC 801-4/1988 (500 V SL, 1000 V PL) IEC 1000-4-5/1995 (2 kV L-E, 1 kV L-L) 	

9. Warranty

Three (3) year warranty is standard on the MN469xC series test sets. Additional warranty is available.

10. Ordering Information

MN4694C		
Description	4-port test set, K connectors	
Coverage	For use with MS4642A/B*: 70 kHz** to 20 GHz For use with MS4644A/B*: 70 kHz** to 40 GHz	
Standard Accessories	Interface cables to base VNA (6 each) GPIB cable to base VNA Power cord Installation instructions (manuals are covered in the base VNA manuals)	
MN4697C		
Description	4-port test set, V connectors	
Coverage	For use with MS4645A/B*: 70 kHz** to 50 GHz For use with MS4647A/B*: 70 kHz** to 70 GHz	
Standard Accessories	Interface cables to base VNA (6 each) GPIB cable to base VNA Power cord Installation instructions (manuals are covered in the base VNA manuals)	

* Base VNA must include the optional Direct Access Loops, available with option 051 or 06x.

** Operational to 40 kHz; Requires Base VNA to include Option 070, otherwise cannot be operated below 10 MHz.

For accessories such as calibration solutions and test port cables, please refer to the base VNA data sheet and configuration guide. All calibration kits that are available for the 2-port VNA are usable with the 4-port solution, including the 2-port precision AutoCal. The available verification kits only support the verification of the 2-port base VNA.

11. Configuration Guide**Minimum 20 GHz 4-Port System Configuration (10 MHz to 20 GHz)**

Part Number	Description	More Information
MS4642A/B	VectorStar 2-port VNA, 10 MHz to 20 GHz	
MS4642A/B-051	Adds Direct Access Loops to base MS4642A/B VNA	Additional options available
MN4694C	4-port test set, K connectors	

Additional items that may be needed:

MS464xA/B-070	70 kHz low end on base VNA	Allows 4-port measurements to 70 kHz (operational to 40 kHz)
3670K50-1	Test port cable, 30 cm, K male to K female	4 pieces recommended (other types exist)
36585K Series	Precision 2-port AutoCal, K connectors	Different connector variations exist
3650A	Cal Kit, SMA/3.5 mm connectors	Different variations exist
33SS50	Adapter: Precision 3.5 mm male to 3.5 mm male	Phase equal series (as many as needed)
33SFSF50	Adapter: Precision 3.5 mm female to 3.5 mm female	Phase equal series (as many as needed)
33SSF50	Adapter: Precision 3.5 mm male to 3.5 mm female	Phase equal series (as many as needed)

Minimum 40 GHz 4-Port System Configuration (10 MHz to 40 GHz)

Part Number	Description	More Information
MS4644A/B	VectorStar 2-port VNA, 10 MHz to 40 GHz	
MS4644A/B-051	Adds Direct Access Loops to base MS4644A/B VNA	Additional options available
MN4694C	4-port test set, K connectors	

Additional items that may be needed:

MS464xA/B-070	70 kHz low end on base VNA	Allows 4-port measurements to 70 kHz (operational to 40 kHz)
3670K50-1	Test port cable, 30 cm, K male to K female	4 pieces recommended (other types exist)
36585K Series	Precision AutoCal 2-port, K	Different connector variations exist
3652A	Cal Kit, K connectors	Different variations exist
33KK50	Adapter: Precision K male to K male	Phase equal series (as many as needed)
33KFKF50	Adapter: Precision K female to K female	Phase equal series (as many as needed)
33KKF50	Adapter: Precision K male to K female	Phase equal series (as many as needed)

Minimum 50 GHz 4-Port System Configuration (10 MHz to 50 GHz)

Part Number	Description	More Information
MS4645A/B	VectorStar 2-port VNA, 10 MHz to 50 GHz	
MS4645A/B-051	Adds Direct Access Loops to base MS4645A/B VNA	Additional options available
MN4697C	4-port test set, V connectors	

Additional items that may be needed:

MS464xA/B-070	70 kHz low end on base VNA	Allows 4-port measurements to 70 kHz (operational to 40 kHz)
3670V50A-1	Test port cable, 30 cm, V male to V female	4 pieces recommended (other types exist)
36585V Series	Precision 2-port AutoCal, V connectors	Different connector variations exist
3654D	Cal Kit, V connectors	Different variations exist
33VV50C	Adapter: Precision V male to V male	Phase equal series (as many as needed)
33VVF50C	Adapter: Precision V female to V female	Phase equal series (as many as needed)
33VVF50C	Adapter: Precision V male to V female	Phase equal series (as many as needed)

Minimum 70 GHz 4-Port System Configuration (10 MHz to 70 GHz)

Part Number	Description	More Information
MS4647A/B	VectorStar 2-port VNA, 10 MHz to 70 GHz	
MS4647A/B-051	Adds Direct Access Loops to base MS4647A/B VNA	Additional options available
MN4697C	4-port Test Set, V connectors	

Additional items that may be needed:

MS464xB-070	70 kHz low end on base VNA	Allows 4-port measurements to 70 kHz (operational to 40 kHz)
3670V50A-1	Test port cable, 30 cm, V male to V female	4 pieces recommended (other types exist)
36585V Series	Precision AutoCal 2-port, V connectors	Different connector variations exist
3654D	Cal Kit, V connectors	Different variations exist
33VV50C	Adapter: Precision V male to V male	Phase equal series (as many as needed)
33VVF50C	Adapter: Precision V female to V female	Phase equal series (as many as needed)
33VVF50C	Adapter: Precision V male to V female	Phase equal series (as many as needed)

Notes



Find Drivers, Utilities, Software Updates, and other Helpful Tools at the VectorStar Users Site. Visit:
www.anritsu.com/en-us/Products-Solutions/Solution/Welcome-to-the-VectorStar-Users-Site-.aspx



Customers in the United States can receive a quote to purchase a product or order accessories by visiting our online ordering site: www.ShopAnritsu.com

Training at Anritsu

Anritsu has designed courses to help you stay up to date with technologies important to your job. For available training courses visit: www.anritsu.com/training



• United States

Anritsu Company

1155 East Collins Blvd, Suite 100,
Richardson, TX 75081, U.S.A.
Toll Free: 1-800-267-4878
Phone: +1-972-644-1777
Fax: +1-972-671-1877

• Canada

Anritsu Electronics Ltd.

700 Silver Seven Road, Suite 120,
Kanata, Ontario K2V 1C3, Canada
Phone: +1-613-591-2003
Fax: +1-613-591-1006

• Brazil

Anritsu Eletrônica Ltda.

Praça Amadeu Amaral, 27 - 1 Andar
01327-010 Bela Vista, São Paulo, Brazil
Phone: +55-11-3283-2511
Fax: +55-11-3288-6940

• Mexico

Anritsu Company, S.A. de C.V.

Av. Ejército Nacional No. 579 Piso 9, Col. Granada
11520 México, D.F., México
Phone: +52-55-1101-2370
Fax: +52-55-5254-3147

• United Kingdom

Anritsu EMEA Ltd.

200 Capability Green
Luton, Bedfordshire LU1 3LU
United Kingdom
Phone: +44-1582-433280
Fax: +44-1582-731303

• France

Anritsu S.A.

12 Avenue du Québec,
Bâtiment Iris 1-Silic 612,
91140 Villebon-sur-Yvette, France
Phone: +33-1-60-92-15-50
Fax: +33-1-64-46-10-65

• Germany

Anritsu GmbH

Nemetschek Haus, Konrad-Zuse-Platz 1
81829 München, Germany
Phone: +49-89-442308-0
Fax: +49-89-442308-55

• Italy

Anritsu S.r.l.

Via Elio Vittorini 129, 00144 Roma, Italy
Phone: +39-06-509-9711
Fax: +39-06-502-2425

• Sweden

Anritsu AB

Kistagången 20B, 164 40 KISTA, Sweden
Phone: +46-8-534-707-00
Fax: +46-8-534-707-30

• Finland

Anritsu AB

Teknobulevardi 3-5
FI-01530 Vantaa, Finland
Phone: +358-20-741-8100
Fax: +358-20-741-8111

• Denmark

Anritsu A/S

Kay Fiskers Plads 9, 2300 Copenhagen S, Denmark
Phone: +45-7211-2200
Fax: +45-7211-2210

• Russia

Anritsu EMEA Ltd.

Representation Office in Russia

Tverskaya str. 16/2, bld. 1, 7th floor
Russia, 125009, Moscow
Phone: +7-495-363-1694
Fax: +7-495-935-8962

• United Arab Emirates

Anritsu EMEA Ltd.

Dubai Liaison Office

P O Box 500413 - Dubai Internet City
Al Thuraya Building, Tower 1, Suite 701, 7th Floor
Dubai, United Arab Emirates
Phone: +971-4-3670352
Fax: +971-4-3688460

• Singapore

Anritsu Pte. Ltd.

11 Chang Charn Road, #04-01, Shiro House
Singapore 159640
Phone: +65-6282-2400
Fax: +65-6282-2533

• India

Anritsu India Private Limited

2nd & 3rd Floor, #837/1, Binnamangla 1st Stage,
Indiranagar, 100ft Road, Bangalore - 560038, India
Phone: +91-80-4058-1300
Fax: +91-80-4058-1301

• P.R. China (Shanghai)

Anritsu (China) Co., Ltd.

27th Floor, Tower A,
New Caohejing International Business Center
No. 391 Gui Ping Road Shanghai, Xu Hui Di District,
Shanghai 200233, P.R. China
Phone: +86-21-6237-0898
Fax: +86-21-6237-0899

• P.R. China (Hong Kong)

Anritsu Company Ltd.

Unit 1006-7, 10/F., Greenfield Tower,
Concordia Plaza,
No. 1 Science Museum Road, Tsim Sha Tsui East,
Kowloon, Hong Kong, P. R. China
Phone: +852-2301-4980
Fax: +852-2301-3545

• Japan

Anritsu Corporation

8-5, Tamura-cho, Atsugi-shi,
Kanagawa, 243-0016 Japan
Phone: +81-46-296-1221
Fax: +81-46-296-1238

• Korea

Anritsu Corporation, Ltd.

5FL, 235 Pangyoyeok-ro, Bundang-gu,
Seongnam-si,
Gyeonggi-do, 463-400 Korea
Phone: +82-31-696-7750
Fax: +82-31-696-7751

• Australia

Anritsu Pty Ltd.

Unit 21/270 Ferntree Gully Road
Notting Hill, Victoria, 3168, Australia
Phone: +61-3-9558-8177
Fax: +61-3-9558-8255

• Taiwan

Anritsu Company Inc.

7F, No. 316, Sec. 1, Neihu Rd, Taipei 114, Taiwan
Phone: +886-2-8751-1816
Fax: +886-2-8751-1817

List Revision Date: 20140624



© Anritsu All trademarks are registered trademarks of their respective companies. Data subject to change without notice. For the most recent specifications visit: www.anritsu.com
Anritsu utilizes recycled paper and environmentally conscious inks and toner.

VectorStar MN469xC Multiport Test Set TDS
Copyright October 2014 Anritsu Company, USA
All Rights Reserved



11410-00777



B